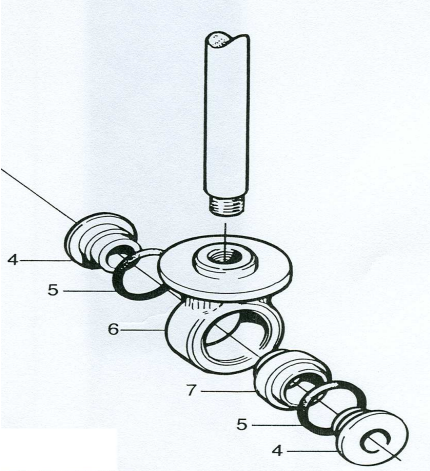
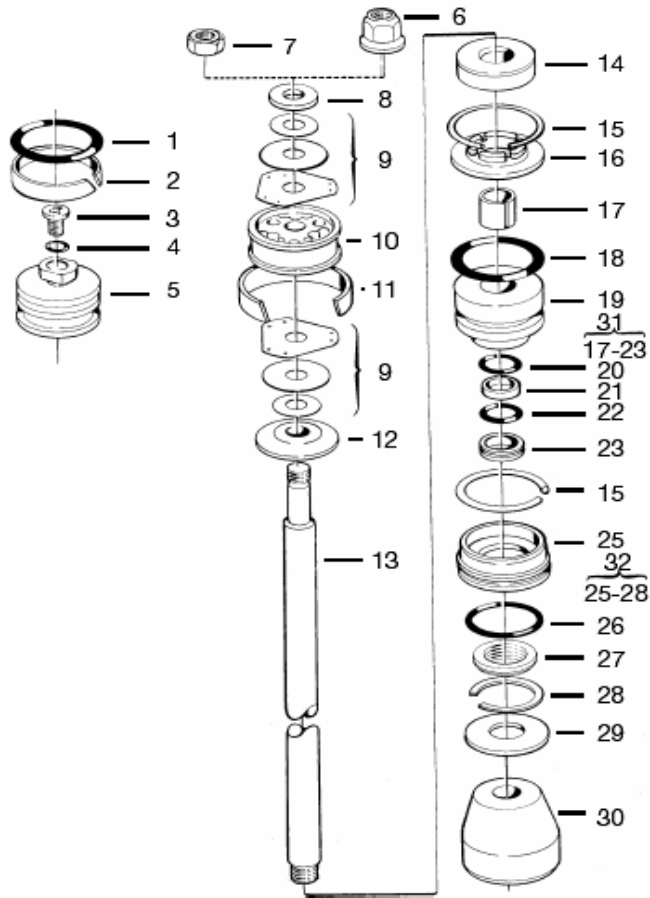

Fig. 01



<i>End eye</i>	S36E	HARLEY DAVIDSON XLH Sportster	HD 916E
<i>Fig no.</i>	<i>Part no.</i>	<i>Description</i>	<i>Qty</i>
01-04	00123-13	Sleeve	1
01-06	00125-01	End eye	1
01-07	00124-10	Rubber bushing	1

Fig.02



Shaft	S36E	HARLEY DAVIDSON XLH Sportster	HD 916E
Fig. no	Part no	Description	Qty
02-06	00139-02	Lock nut	1
02-08	00120-01	Washer	1
02-09		Shim stack see spec card	
02-10	00104-18	Piston	1
02-11	03078-01	Piston ring	1
02-12	00119-05	Stop washer	1
02-13	00101-01	Shaft	1
02-14	03144-02	Spacer	1
02-14	03144-03	Spacer	6
02-15	00128-01	Circlip	2
02-16	00133-01	Stop rubber	1
02-17	00110-03	Bushing	1
02-18	00338-09	O-ring	1
02-20	00338-08	O-ring	1
02-21	00117-01	Seal	1
02-22	00338-10	O-ring	1
02-23	00122-01	Scraper	1
	00338-05	O-ring for scraper	1
02-30	00163-15	Bump rubber	1
02-31	00121-01	Seal head assy	1
02-32	00165-02	End cap	1

Fig. 03

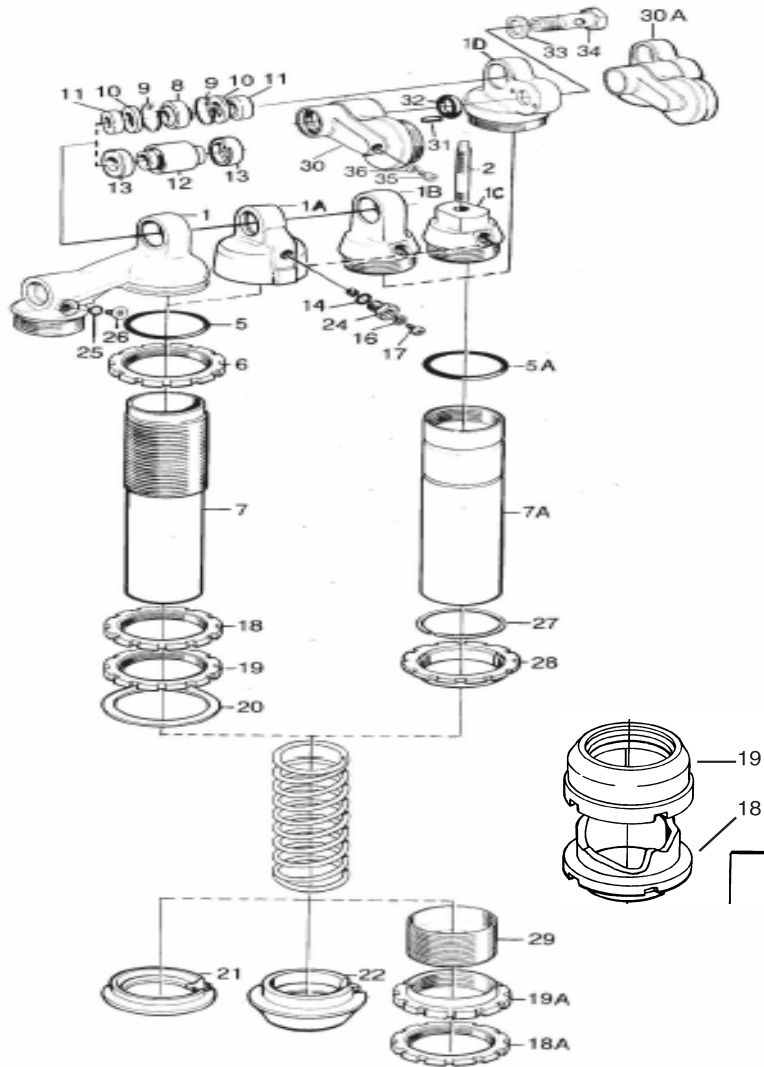

Body tube	S36E	HARLEY DAVIDSON XLH Sportster	HD 916E
Fig no.	Part no.	Description	Qty
03-00	00196-01	Sticker Varning	1
03-01	00201-22	Cylinder head	1
03-05	00338-02	O-ring	1
03-07	03300-18	Cylinder tube	1
03-12	00124-10	Rubber bushing	1
03-13	00123-13	Sleeve	1
03-14	00338-07	O-ring	1
03-16	00338-59	O-ring	1
03-17	01050-01	Screw	1
03-18	00416-04	Cam adjuster	1
03-19	00415-04	Adjustment ring	1
03-21	00116-04	Spring clip	1
03-24	00603-03	Valve assy	1
03-27	00131-01	Ciclip	1
	00417-02	Protector cylinder tube	1
	00480-02	Main spring	1