

👁 Note!

Please note that there can be small differences between your product and the images in these instructions.

👁 Note!

Please note that during storage and transport, especially at high ambient temperature, some of the oil and grease used for assembly may leak and stain the packaging. This will not cause damage to the product, wipe off the excessive oil or grease with a cloth.

Kit Contents

Description	Part No	Pcs
Tie-rop	00231-01	2
Screw MC6S 8x50	01046-25	1
Sticker Memo notes	01180-01	1
Sticker Öhlins wh/tr	01185-01	2
Sticker Öhlins bl/tr	01185-04	2
Owner's manual	07242-05	1

👁 Note!

Before you install this product, check the kit contents. If anything is missing, please contact an Öhlins dealer.

⚠ Warning!

Before you install this product, read the Öhlins Owner's manual. This product is an important part of the vehicle and the vehicle stability.

Shock absorber for Kawasaki H2

KA 363

Mounting Instructions



MOUNTING INSTRUCTIONS

⚠ Warning!

We strongly recommend to let an Öhlins dealer install this product.

⚠ Warning!

If you work with a lifted vehicle, make sure that it is safely supported to prevent it from tipping over.

👁 Note!

When you work with this product, see the vehicle service manual for vehicle specific procedures and important data.

👁 Note!

Before you install this product clean the vehicle.

- 1**
Put the bike on a stand so that the rear wheel is off the ground.
- 2**
Loosen the lower shock absorber mounting bolt.
- 3**
Loosen the bolt connecting the pull rods and the triangular link. Loosen the bolt connecting the triangular link to the swing arm and remove the triangular link.
- 4**
Loosen the upper shock mounting bolt, lift up the swing arm, remove the upper mounting bolt and remove the standard shock absorber downward through the swing arm.
- 5**
Mount the Öhlins unit by first pulling up the pre-load adjuster through the swing arm, followed by the shock absorber. Fit the upper mounting screw.
- 6**
Mount the lower shock absorber mounting bolt. Mount the triangular link bolts.
- 7**
Lower the bike and tighten all shock and linkage mounting bolts to the correct torque according to the bike service manual.
- 8**
Install the hydraulic pre load adjuster at the inside of the silencer bracket. Use the supplied M8x50 screw. To re-use the standard washer it needs to be pressed off from the standard screw. See figure.
- 9**
Tie up the hose with the supplied ty-raps.
- 10**
Check that there are no clearance problems when the rear suspension is moving and that all screws are tightened before riding the bike.

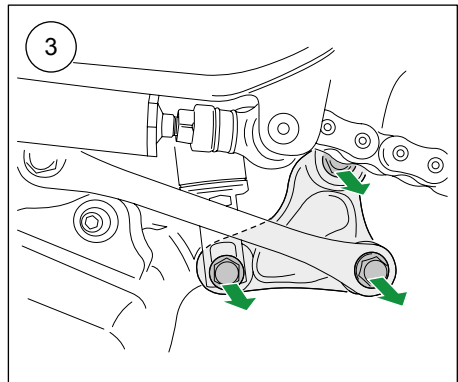

MOUNTING INSTRUCTIONS

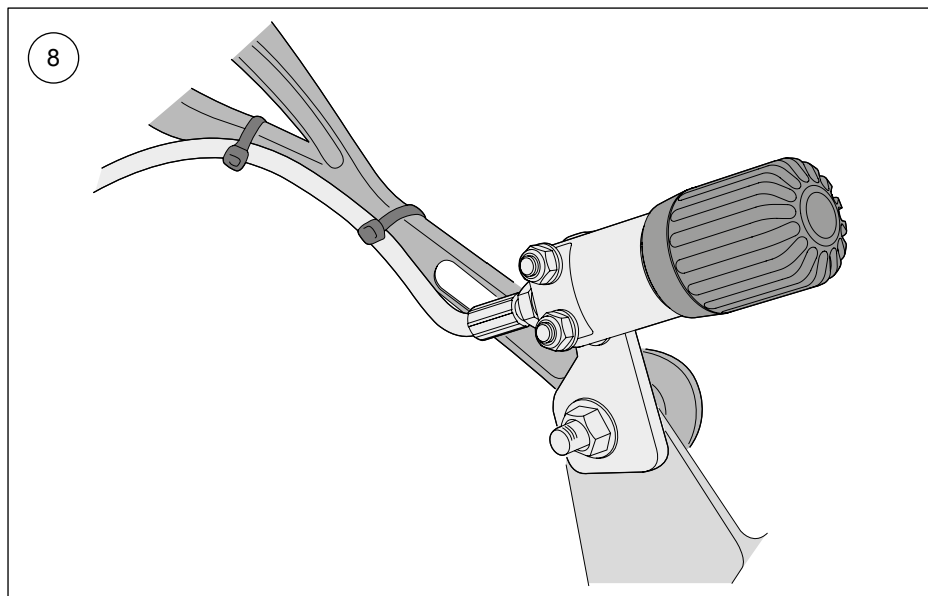
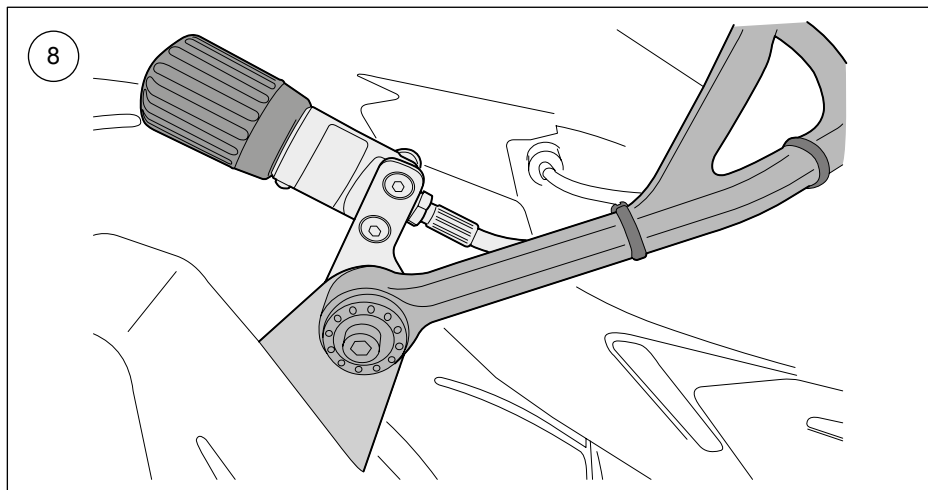

ADJUSTMENTS

⚠ Warning!

Before you ride/drive, always make sure that the setup is according to the recommended setup data. Read about adjustments and setting up in the Öhlins Owner's Manual before you make any adjustments. Contact an Öhlins dealer if you have any questions about setting up.

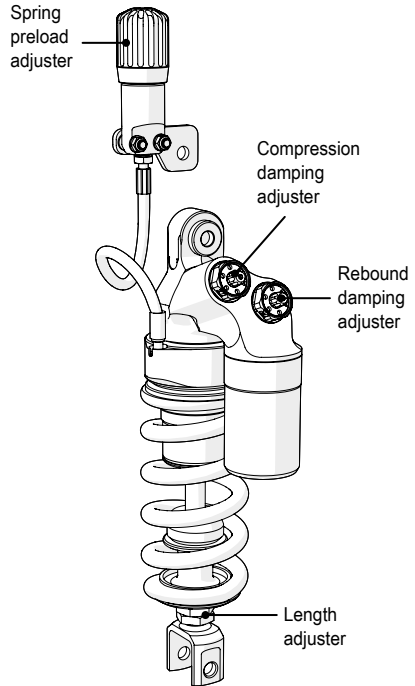

SETUP DATA

Length	309 +5/-1	mm
Stroke	57	mm
Rebound	12	clicks
Compression	12	clicks
Spring preload	14 (+5/-3)	mm
Spring	21040-44	
Spring rate	120	N/mm
Spring length	160	mm

Recommended ride height		
R1-R3	35	mm
F1-F3	42	mm

Öhlins products are subject to continuous improvement and development, therefore, although these instructions include the most up-to-date information available at the time of printing, minor updates may occur.

To find the latest information contact an Öhlins distributor. Please contact Öhlins if you have any questions regarding the contents in this document.

Part no. MI_KA363_0
Issued 2016-04-18

© Öhlins Racing AB. All rights reserved. Any reprinting or unauthorized use without the written permission of Öhlins Racing AB is prohibited.

Öhlins Racing AB
Box 722
S-194 27 Upplands Väsby, Sweden
Phone +46 8 590 025 00
fax +46 8 590 025 80



www.ohlins.com