



*After market Kit for Ducati Multistrada 1200*  
***DU 870/871***

**Owner's Manual/ Mounting Instructions**



*Öhlins Headquarters Upplands Väsby, Sweden*

### **Öhlins Racing AB - The Story**

It was the 1970's, a young man named Kenth Öhlin spent most of his spare time pursuing his favourite sport: motocross.

Being a careful observer, Kenth's attention was continuously drawn to one specific detail - motocross bikes had more engine power than their suspension could handle. It was not long before Kenth realised that better performance could be achieved by improved wheel suspension.

Öhlins Racing was established in 1976, and just two years later the company won its first World Championship title. Despite being in the business for 35 years, the search for perfection and new functions is still the main focus of the company.

*Congratulations!* You are now the owner of an Öhlins product. More than two hundred World Championships and other major world titles are definitive proof that Öhlins suspension offers outstanding performance and reliability.

Every product has gone through rigorous testing and engineers have spent thousands of hours, doing their very best to use every possible experience from our 35 years within the racing sport.

The product that you now have in your possession is pure racing breed that is built to withstand.

By installing this product on your vehicle you have made a clear statement... you are a serious rider with a focus on getting the maximal handling ability and outstanding feedback from your vehicle. Along comes the fact that your shock absorber will be a long lasting friend, delivering the very best of comfort and performance every time you go for a ride. Go explore!

# BEFORE YOU BEGIN

## **⚠ Warning!**

Before installing this product, read the Safety Precautions and the information in this manual thoroughly. The shock absorber/front fork/steering damper is an important part of your vehicle and will affect the stability.

## **👁 Note!**

Before installing this product, check the contents of the kit. If anything is missing, please contact an Öhlins dealer.

## **Kit Contents**

<b>Description</b>	<b>Part No</b>	<b>Pcs</b>
Shock absorber	DU869	1
Front fork	FG868	1
Sticker Mechatronic Syst.	00191-46	2
Tie rap	00231-01	20
Sticker Öhlins	01185-01	2
Setting card	01199-01	1
Screw M5x12	04757-10	4
Wire harness	21770-04	1
Electr. tap conn.22-16 AWG	21310-01	1
Fender bracket	21644-02	2
Bracket - preload adj.	21869-01	1
Screw - preload adj.	21869-02	2
Rubber - preload adj.	21869-03	2
Rubber bracket SCU	21869-04	1
SCU	35000-02	1
Dashboard	35007-02	1

# TABLE OF CONTENTS

<b>SAFETY PRECAUTIONS</b> .....	<b>4</b>
<b>1 DESIGN</b> .....	<b>5</b>
<b>2 MOUNTING INSTRUCTIONS</b> .....	<b>6</b>
2.1 Before you begin .....	6
2.2 Install the Öhlins Front Fork .....	6
2.3 Install the Öhlins Shock Absorber .....	7
2.4 Install the SCU .....	9
2.5 Install the Öhlins Dashboard .....	9
2.6 Install the Wire Harness .....	10
2.7 Install the Electrical Tap Connector .....	11
2.8 After Installation .....	11
<b>3 SPRING PRELOAD</b> .....	<b>12</b>
<b>4 DASHBOARD USER GUIDE</b> .....	<b>13</b>
4.1 Introduction .....	13
4.2 Screen navigation .....	14
4.3 Calibrate Spring Preload .....	14
4.4 Dashboard Menus .....	15
4.5 Load Mode .....	16
4.6 Recommended Settings .....	16
4.7 Settings Menu .....	17
<b>5 INSPECTION AND MAINTENANCE</b> .....	<b>18</b>

# SAFETY PRECAUTIONS

## General Warnings

### **Note!**

*The shock absorber/front fork/steering damper is an important part of the vehicle and will affect the stability.*

### **Note!**

*Read and ensure you understand the information in this manual and other technical documents provided by Öhlins, before using the product.*

### **Note!**

*Öhlins Racing AB can not be held responsible for any damage to the shock absorber/front fork/steering damper, vehicle, other property or injury to persons, if the instructions for mounting, usage and maintenance are not followed exactly.*

### **Warning!**

*After installing the Öhlins product, take a test ride at low speed to ensure your vehicle has maintained stability.*

### **Warning!**

*If the suspension makes an abnormal noise, or the function is irregular, or if you notice any leakage from the product, stop the vehicle immediately and return the product to an Öhlins dealer.*

### **Warning!**

*The product warranty shall only apply if the product has been operated and maintained in accordance with recommendations in this manual. If you have any questions regarding usage, service, inspection and/or maintenance please contact Öhlins.*

### **Note!**

*When working with the Öhlins product, always read the vehicle service manual.*

### **Note!**

*This manual shall be considered as a part of the product and shall accompany the product throughout its life cycle.*

## SAFETY SYMBOLS

*In this manual, mounting instructions and other technical documents, important information concerning safety is distinguished by the following symbols:*



*The Safety Alert Symbol means: Warning! Your safety is involved.*

### **Warning!**

*The Warning Symbol means: Failure to follow warning instructions can result in severe or fatal injury to anyone working with, inspecting or using the shock absorber, or to bystanders.*

### **Caution!**

*The Caution Symbol means: Special precautions must be taken to avoid damage to the shock absorber.*

### **Note!**

*The Note Symbol indicates information that is important regarding procedures.*

## Product Specific Warnings

### **Warning!**

*This product was developed and designed exclusively for a specific vehicle model and shall only be installed on the intended vehicle model in its original condition as delivered from the vehicle manufacturer.*

© Öhlins Racing AB. All rights reserved.  
Any reprinting or unauthorized use without the written permission of Öhlins Racing AB is prohibited.

# 1 DESIGN

*Congratulations on your purchase of the After market Kit for Ducati Multistrada 1200 and thank you for choosing Öhlins Suspension Technology.*

*The system by Öhlins consists of a TTX shock absorber, NIX front fork, dashboard, SCU and a wire harness. This electronically controlled (EC) system merges smart functions such as pre programmed riding modes with different damping characteristics to suit your speed and riding behaviour.*

## **The TTX EC Concept**

The possibility to adjust damping settings during travel has been somewhat of a dream. Now Öhlins Racing has solved the problem with the TTX EC concept, also called Mechatronics. Well tested algorithms control the damper settings depending on, for instance, the speed.

You can change damper settings on the dashboard while riding thanks to the micro-controller in combination with the stepper motor. Like a remote control that controls the rebound and compression settings on the shock absorber and front fork.

## **The EC Software**

The EC software from Öhlins provides different riding modes for the rider.

## **The Suspension Control Unit (SCU)**

Öhlins SCU is a compact electronic control unit designed for embedded real time suspension control applications. It controls several stepper motors and one DC motor with position feedback.

## **The TTX EC Shock Absorbers**

The TTX is a twin tube shock absorber and always has a positive damping pressure build up, it is therefore ideal to equip with EC adjusters. In other words, the pressure is always raised to create damping, independently of how the bleed is adjusted. Nitrogen pressure can then be low, which gives low friction. The adjustment range is wide for both compression and rebound damping, you set the adjusters from the Öhlins dashboard.

## **The Preload Adjuster EC**

The preload adjuster EC is a light and tiny unit that offers superior performance versus size ratio. It is a traditional remote hydraulic preload adjuster but with a DC motor adjusting the spring preload controlled by the Öhlins SCU, instead of a manually operated adjuster. The system also provides information of the preload position to get optimum setup for different conditions and circumstances, for example when having a passenger and/or luggage.

## **The Front Fork EC System**

In an EC-adjusted front fork the adjustment needle is activated by an electrical stepper motor. Control the EC-motors from the Öhlins dashboard.

# 2 MOUNTING INSTRUCTIONS

## Mounting Instructions

2.1 Before you begin.....	6
2.2 Install the Öhlins Front Fork.....	6
2.3 Install the Öhlins Shock Absorber.....	7
2.4 Install the SCU.....	8
2.5 Install the Öhlins Dashboard.....	8
2.6 Install the Wire Harness.....	10
2.7 Install the Electrical Tap Connector.....	11
2.8 After Installation.....	11

## 2.1 Before you begin

### **⚠ Warning!**

*It is advisable to have an Öhlins dealer install the shock absorber/front fork/steering damper.*

### **⚠ Warning!**

*If working on a raised vehicle, ensure it is securely supported so that it will not tip.*

### **👁 Note!**

*Before mounting this product clean the vehicle thoroughly.*

### **👁 Note!**

*When working on this product, always see the Vehicle Service Manual for vehicle specific procedures and important data.*

## 2.2 Install the Öhlins Front Fork

### 2.2.1

Put the motorcycle on a work stand so that the rear wheel barely touches the ground.

### 2.2.2

Remove the front fender.

### 2.2.3

If ABS-version, remove the ABS sensor from the left fork bottom.

### 2.2.4

Remove the brake calipers and the front wheel.

### 2.2.5

Remove the original front fork.

### 2.2.6

Install the Öhlins front fork. Position the fork leg so that 10 mm of the golden colored outer tube is visible above the upper triple crown.

Compression fork leg	left side
Rebound fork leg	right side

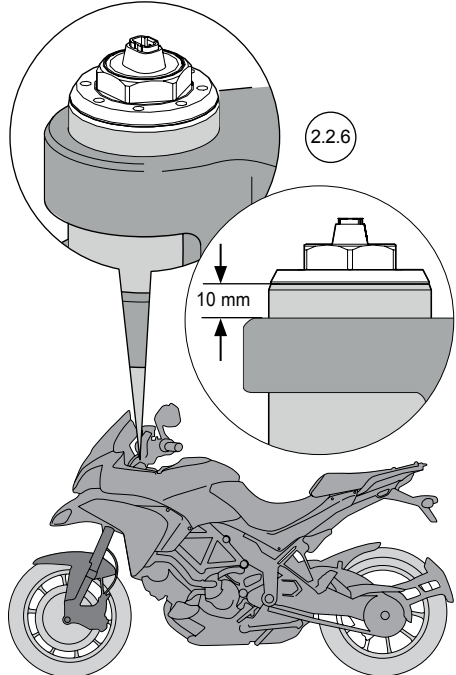

# 2 MOUNTING INSTRUCTIONS

## 2.2.7

Install the fender brackets (21644-02) with the screws (04757-10) provided in the kit. Tightening torque 5-7 Nm. Use thread locking fluid, Loctite 243 or similar on the screws.

## 2.2.8

Reinstall the wheel, brake calipers, ABS sensor (if any) and front fender. Tightening torque according to vehicle service manual.

### **Note!**

*Assemble the four M8-screws clamping the wheel axle to 19Nm torque. Tighten in a 1-2-1 sequence on each side (1-2-1 sequence: tighten the first screw, then the other screw, then finish by tightening the first screw again).*

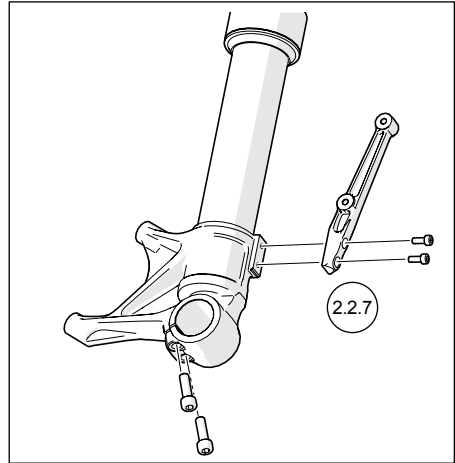

## 2.3 Install the Öhlins Shock Absorber

### 2.3.1

Remove both seats.

### 2.3.2

Assemble the brackets for the preload adjuster motor according to the figure.

### 2.3.3

Remove the left panel, below the seat area.

### 2.3.4

Remove the swing arm fender.

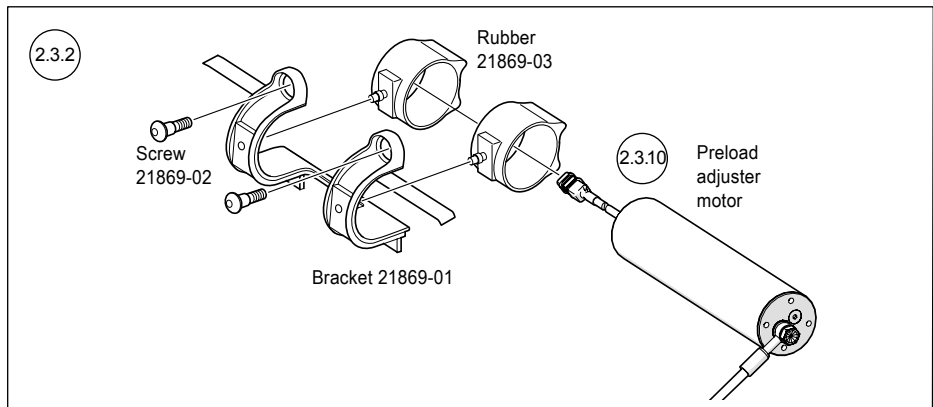
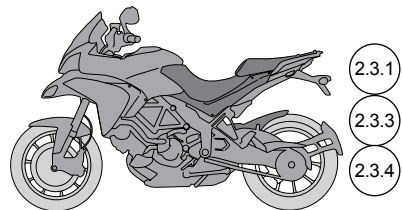

# 2 MOUNTING INSTRUCTIONS

## 2.3.5

Remove the original preload adjuster.

## 2.3.6

Remove the lower and upper attachments of the original shock absorber. Remove the original shock absorber.

## 2.3.7

Remove the upper left screw to the rear sub frame.

## 2.3.8

Install the Öhlins shock absorber. Use the original screws for the upper and lower attachments. Compress the suspension slightly before tightening. Tightening torque according to vehicle service manual.

## 2.3.9

Use appropriate tool and carefully bend the upper left point of the rear sub frame, just enough to squeeze the preload adjuster hose between the frame and the rear sub frame.

## 2.3.10

Install the preload adjuster motor in the rubber mounts assembled in step 2.

## 2.3.11

Reinsert the upper left screw to the rear sub frame. Tightening torque according to vehicle service manual.

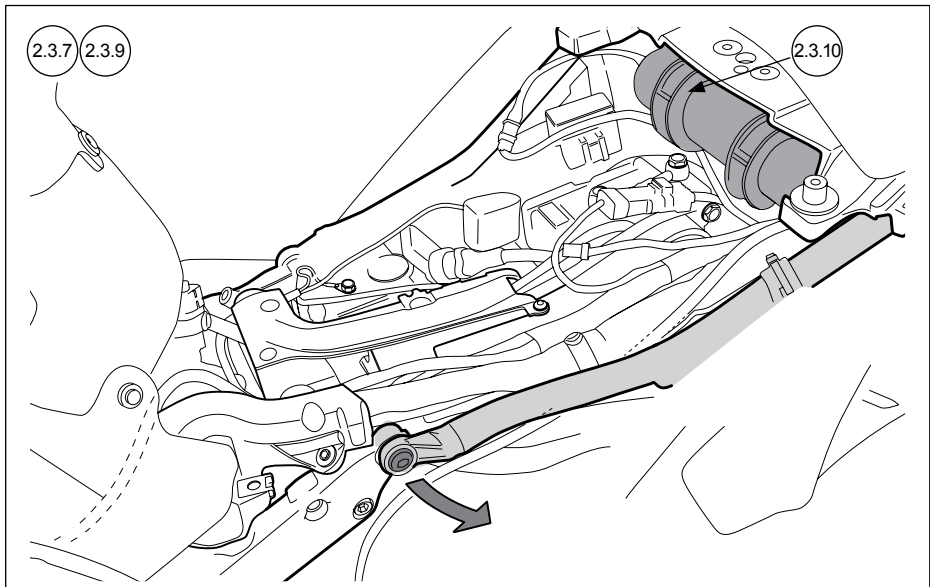



# 2 MOUNTING INSTRUCTIONS

## 2.4 Install the SCU

### 2.4.1

Insert the Öhlins SCU into the rubber mount provided with the kit.

### 2.4.2

Fasten the rubber mount with the SCU on the left side of the rear sub frame. Use tie raps to fasten.

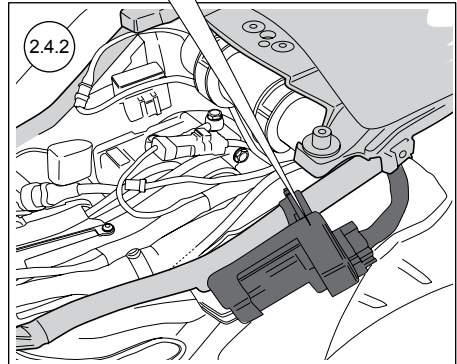
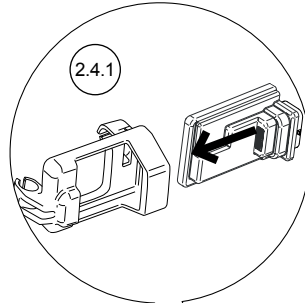

## 2.5 Install the Öhlins Dashboard

### 👁 **Note!**

*Be thorough when fastening the dashboard to the hook and loop fastener, once attached it will be hard to move.*

### 2.5.1

Fasten the dashboard to the handlebar top clamp using the supplied hook and loop fastener.

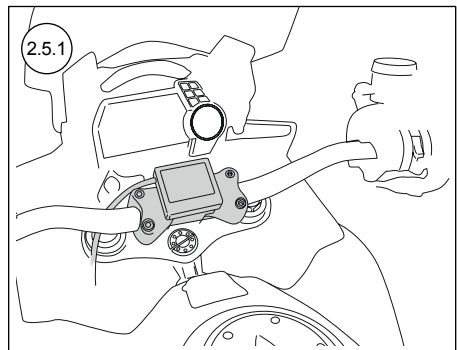

# 2 MOUNTING INSTRUCTIONS

## 2.6 Install the Wire Harness

### 2.6.1

Remove the air deflector on the left side.

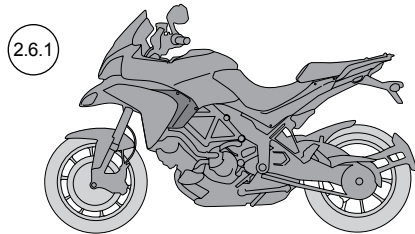

### 2.6.2

Connect the connectors/cables, but not K1 and K2 yet, according to the schematic figure. Note that D shall not be connected.

### 2.6.3

Fasten the cables with the tie raps provided, where needed. Ensure that the cables to the front fork are not stretched, also make sure not to fasten the cables close to the shock absorber since the tie raps can prevent the parts from moving freely.

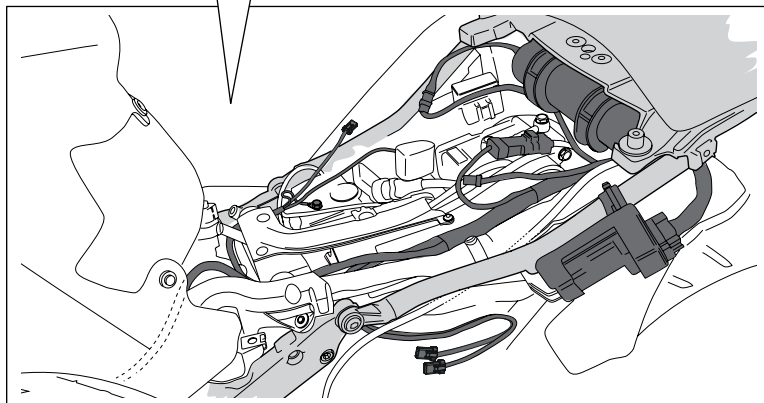
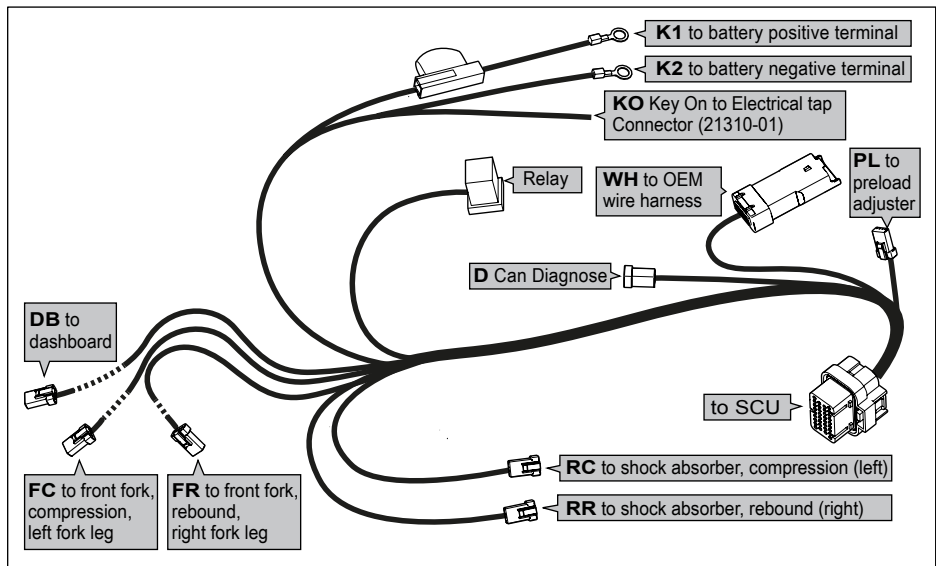

# 2 MOUNTING INSTRUCTIONS

## 2.7 Install the Electrical Tap Connector

### **⚠ Warning!**

*Do not perform the following steps with the battery terminals (K1 and K2) connected.*

#### **2.7.1**

Cut a 30mm incision in the cover of the 12V power supply outlet cable. Locate the red/blue cable.

#### **2.7.2**

Insert the red/blue cable and the KO cable according to the figure. Ensure that the KO cable is inserted until stop.

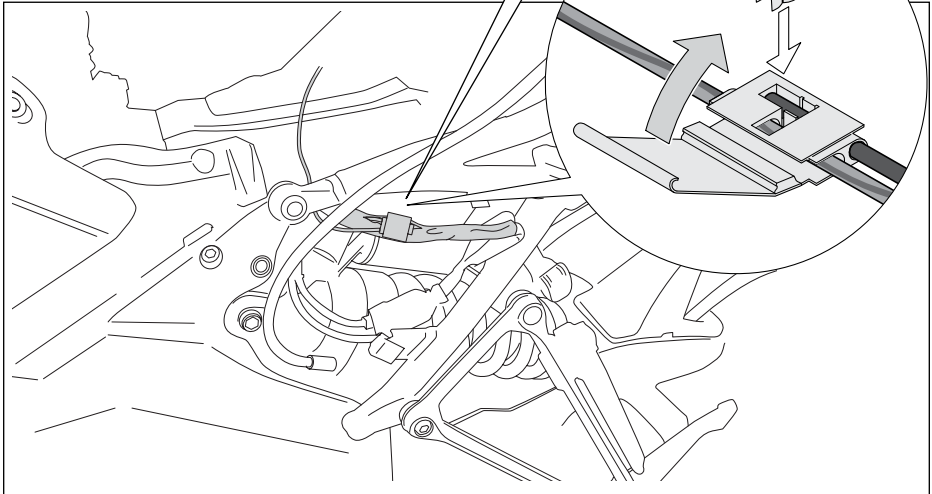

#### **2.7.3**

Use pliers to gently seal the electrical tap connector. Ensure that the lid is firmly closed, you will hear a noticeable click.

#### **2.7.4**

Put electrical tape around the cable and the electric tap connector to protect and to help them stay in place.

## 2.8 After Installation

Ensure that all removed parts are reinstalled according to vehicle service manual.

### **⚠ Caution!**

*Ensure that all screws are tightened to the correct torque and that nothing fouls or restricts movement of the shock absorber/front fork/steering damper when the suspension is fully compressed or extended.*

# 3 SPRING PRELOAD

*When adjusting the spring preload you move the spring seat. This will decrease or increase the initial spring force, which will lower or raise the motorcycle ride height.*

The spring preload is fundamental for the function of the suspension. If the preload is incorrectly set, any other adjustments will not help to get the intended performance from the suspension.

## 3.1 Adjust Spring Preload

### Front (Front Fork)

1

Disconnect the EC cables.

2

Use a 32 mm wrench. Turn counter clockwise to fully open, position 0. Turn clockwise and count the turns until you reach the desired preload.

### Recommended Spring Preload

Front fork Spring preload     6 mm

### Rear (Shock Absorber)

Adjust spring preload on the dashboard.

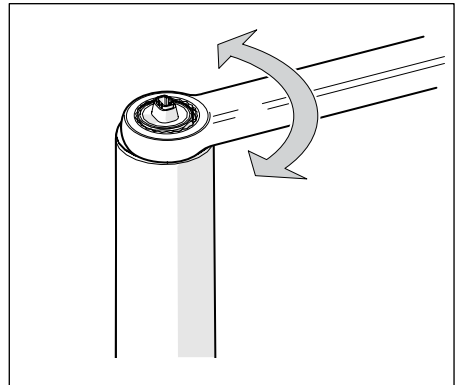
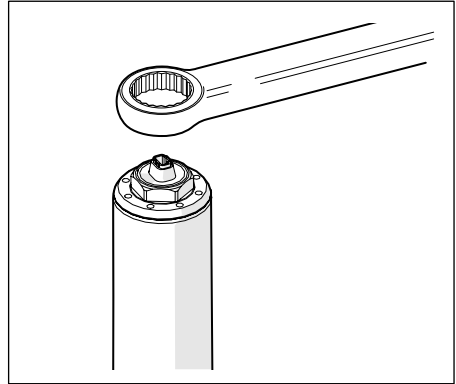

# 4 DASHBOARD USER GUIDE

## 4.1 Introduction

The Öhlins Dashboard features an intuitive touch screen interface designed to make navigation easy for everyone. With the dashboard the rider can easily switch between the different suspension characteristics maps for the three riding modes; urban, touring and sport. Within each riding mode you can then easily change and edit the setup for the front and rear suspension, brake support, speed support and load mode.

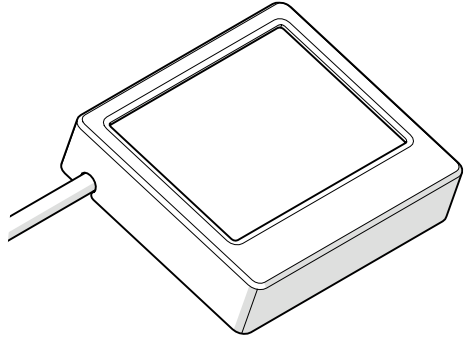

### **Note!**

*After installation calibrate the spring preload. Go to chapter 4.3.*

## Start Up Screen

Activate the dashboard. The start up (1) and warning (2) screen light up.

1



2



## How to Navigate

Press the touch screen to navigate. Note that the dashboard also works if wearing a glove.

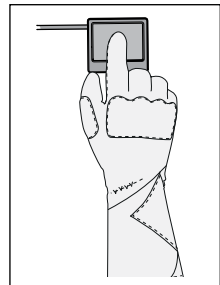
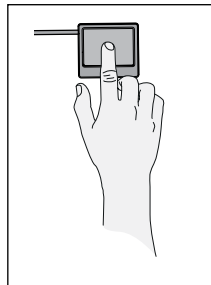

# 4 DASHBOARD USER GUIDE

## 4.2 Screen navigation

A Arrows up/down to navigate in the menu.

B Pressure area.

Short press	Toggle within menu
Long press	Enter menu to change setting

C Return arrow/ Confirm

D Error indication - *Contact Öhlins*

E Load mode

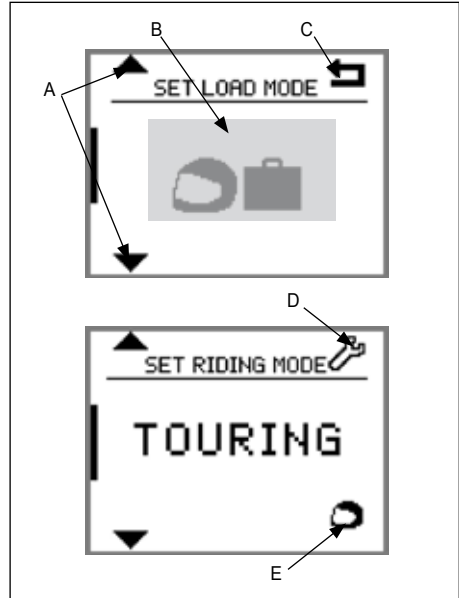

## 4.3 Calibrate Spring Preload

### 👁 Note!

*After installation always calibrate the spring preload.*

### 4.3.1

Switch the ignition on, and at the same time press (long press) on the dashboard screen. The dashboard lights up and the screen shows SETTINGS menu.

### 4.3.2

Press the arrows up/down and choose CAL SPRING PRELOAD.

Press the arrow to the right and the calibration starts.

### 4.3.3

After calibration press return arrow to go to the SETTINGS menu.

### 4.3.4

Press the return arrow once more to exit the SETTINGS menu.

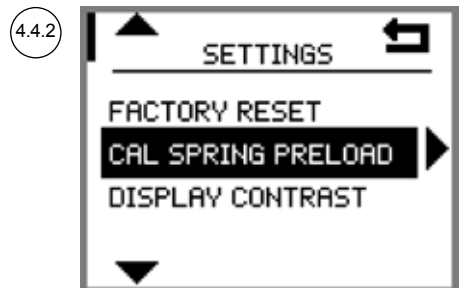

4.4.2

# 4 DASHBOARD USER GUIDE

## 4.4 Dashboard Menus

### 4.4.1 Riding Mode

There are 3 riding modes;

- URBAN
- TOURING
- SPORT

#### To change riding mode;

Press the arrows up/down (1) or short press in the middle of the screen (2) to toggle between the three modes.

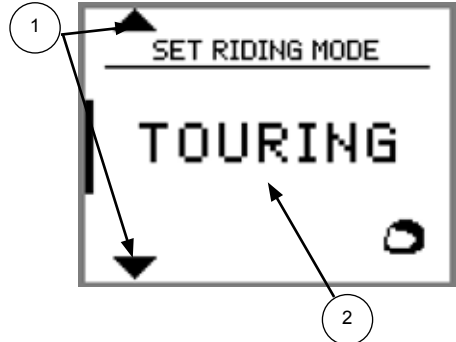

#### Change setting within a riding mode

Long press in the middle of the screen (on URBAN, TOURING or SPORT) to enter the setting in the riding mode.

Press the arrows up/down to toggle between the different setup selections. Press the return button to confirm.

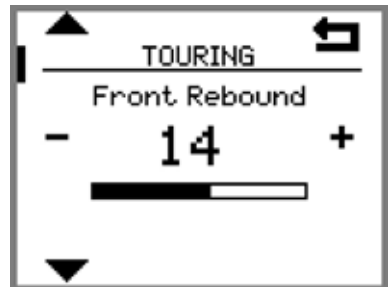

Setup Selections		
<b>Front Compression</b>		
<b>Front Rebound</b>		
<b>Rear Compression</b>		
<b>Rear Rebound</b>		
<b>Spring Preload</b>		
<b>Speed function</b>	OFF	No speed function is used
	1	Very soft at low speed, soft at high speed
	2	Very soft at low speed, medium at high speed
	3	Medium at low speed, stiff at high speed
<b>Acceleration function</b>	OFF	No acceleration function is used
	1	Medium grip and stability optimization
	2	Aggressive grip and stability optimization
<b>Brake function</b>	OFF	No brake function is used
	1	Medium brake optimization
	2	Aggressive brake optimization

# 4 DASHBOARD USER GUIDE

## 4.5 Load Mode

There are 3 load modes;

Rider only (A)

Rider with luggage (B)

Rider and passenger (C)

### To change load mode;

Long press on the load mode symbol.

Navigate between the three load modes with the arrows up/down or with short press in the middle of the screen. Press the return button to confirm and go back to main menu.

### 👁 Note!

*Load mode only changes preload, adjust settings according to the table in chapter 4.6 (or the Setting Card provided in this kit).*

## 4.6 Recommended Settings

Base click settings; Front Compression, Front Rebound, Rear Compression, Rear Rebound

### 👁 Note!

*Speed function over rides base click settings. If speed function is set to off, use base click settings.*

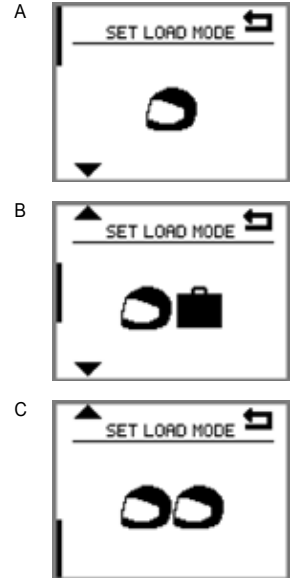

## Delivery Settings

	URBAN	TOURING	SPORT
Base click settings	24, 24, 24, 24	18, 14, 16, 16	6,10,10,12
Speed function	1	2	Off
Acceleration function	Off	Off	1
Brake function	Off	Off	1

## Luggage/ Passenger Recommendations

	URBAN	TOURING	SPORT
Base click settings	18,14,16,16	14, 14,10,12	6,10,6,12
Speed function	2	3	Off
Acceleration function	Off	Off	1
Brake function	Off	Off	1

## Track Recommendations

			SPORT
Base click settings			2,8,4,8
Speed function			Off
Acceleration function			1 or 2
Brake function			1 or 2



# 4 DASHBOARD USER GUIDE

## 4.7 Settings Menu

To reach the Settings menu switch the ignition on and press, long press, the screen.

There are 6 different selections in the settings menu;

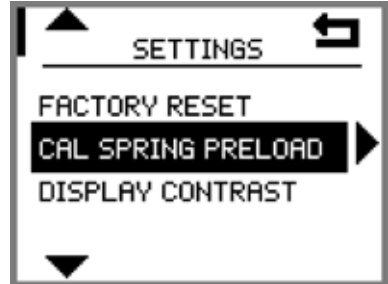

<b>CAL SPRING PRELOAD</b>	Calibrate spring preload. Performed after installation.
<b>DISPLAY CONTRAST</b>	Adjust the display contrast (0-100%)
<b>ACTIVE BACKLIGHT</b>	Adjust the display backlight in “active mode” (0-100%)
<b>INACTIVE BACKLIGHT</b>	Adjust the display backlight in “active mode” (0-100%)
<b>ACTIVE TIMEOUT</b>	Adjust the time that the display is active. 0.0 turns of the “inactive mode” [0.5-60.0 s)
<b>FACTORY RESET</b>	Resets all to factory settings.

# 5 INSPECTION AND MAINTENANCE

*Preventive maintenance and regular inspection reduces the risk of poor performance. If there is any need for additional service, please contact Öhlins.*

## Cleaning

Clean externally with a soft detergent. Use compressed air. Ensure that all dirt is removed. Keep the shock absorber/front fork clean and spray it with oil (WD40, CRC 5-56 or equivalent) after washing. Wipe off excessive oil with a cloth.

## ⚠ Caution!

*Never use strong detergents that can damage the surfaces. Thinner and brake cleaner will dry out seals, increase the risk of friction, oil leakage or even malfunction. Never spray water directly into the adjuster knobs and/or ball joints.*

## 👁 Note!

*Öhlins products should only be filled with Öhlins High Performance Shock Absorber/Front Fork Fluid. Contact Öhlins for advice.*

## ⚠ Warning!

*Never alter gas pressure. Special purpose charging equipment and access to nitrogen is required.*

## Inspection points

### Shock Absorber

1. Check ball joints for possible excessive play or stiction.
2. Check the piston shaft for leakage and damage.
3. Check the shock absorber body for external damage.
4. Check the reservoir for external damage that can restrict the floating piston from moving freely.
5. Check for excessive wear of rubber components.
6. Check the attachment points of the shock absorber to the vehicle.
7. Check the electrical wires and connectors for external wear or damages.

### Recommended Service Intervals

Regular street use: Every 30 000 km

Track:                   Every 10 hours of operation.  
                              Maximum 20 hours of operation  
                              without service and oil change.

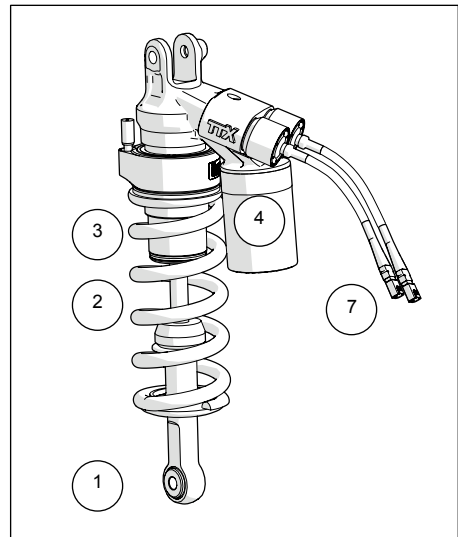

# 5 INSPECTION AND MAINTENANCE

## Front Fork

1. Check for external oil leakage.
2. Check the inner fork leg for scratches, dents or other defects (that might harm the seal/bushing).
3. Check fastening of fender brackets and brake caliper.
4. Check fastening to the vehicle.

## Recommended Service Intervals

Regular street use: Once a year or every 5000 km

Race track: Every 10 hours

## Once every 2nd year (or 20 000 km)

Change the front fork oil. Remove outer fork leg and inspect the bushings, seals and the full length of the inner fork leg. Replace the seals and bushings if necessary. Proceed according to Öhlins Workshop manual.

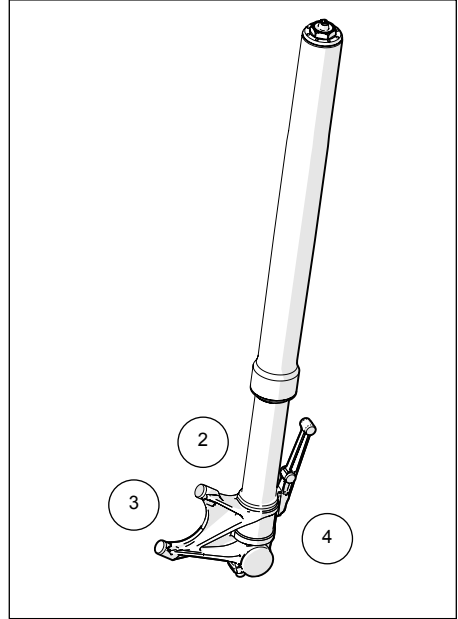



Your Öhlins retailer:

Öhlins Racing AB  
Box 722  
SE-194 27, Upplands Väsby  
Sweden

Phone: +46 (0)8 590 025 00  
Fax: +46 (0)8 590 025 80  
[www.ohlins.com](http://www.ohlins.com)

